



HF FOG 65/130 - BATTERY

ITEM # _____

MODEL # HF FOG65 & HF FOG130

Features

- Rechargeable Battery
- Reversible Motor/Pump
- 65 lb. & 130 lb. Capacity
- Completely self contained unit
- Easily moveable
- No messy electrical cord.
- No lifting

Description

All Filtrator F.O.G. units are completely self-contained into one compact mobile unit. The container, handle and Power Unit are stainless steel. All other exterior surfaces are nickel-plated steel. The pump is specially machined to handle high temperature edible oils. The specially fabricated hose is designed for the same purpose with embedded wire reinforcement. The screen nozzle assembly can be used on almost every fryer, gas or electric. The pump and motor are reversible.

Electrical Specifications

Motor: 12 V, 2.3 AMP DC
 Battery: Rechargeable, maintenance free 12 V DC
 Fuse/Fuseholder: 12 VT 15A

Standard Accessory

Battery Charger – rated at 120 VAC input, 12 VDC 750MA output. – 8 hour charge = 10 hours operation
 1 PEEK Filter (FA07) – FOG 65 Only
 Filter Powder Packets (FP22D) 25 each – FOG 65 Only



R.F. Hunter Co., Inc. has been designing, selling and servicing commercial quality filtrators for over 60 years. We offer a full range of models and sizes to accommodate 65 lb. and 130 lb. F.O.G. units and replacement parts.

R.F. HUNTER CO., INC. F.O.G BATTERY

ITEM # _____

R.F. HUNTER CO., INC.
SPECIALISTS IN KITCHEN ECONOMY SINCE 1945

MODEL #: HF FOG65 & HF FOG130

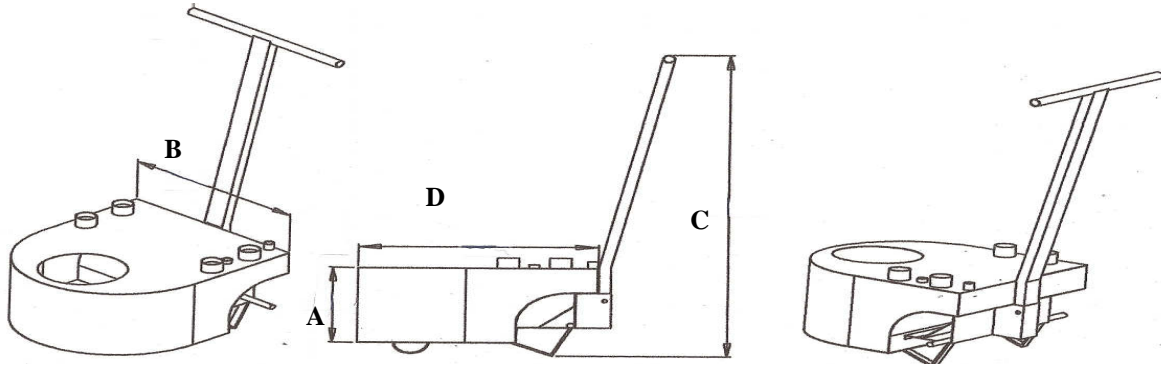

R.F. HUNTER CO., INC. F.O.G. BATTERY

	MODEL HF FOG65	MODEL HF FOG130
DIMENSION FROM FLOOR		
A	11.75"	20.25"
B	18.00"	18.00"
C	41.90"	41.90"
D	20.00"	20.00"
CONTAINER CAPACITY	65 lbs.	130 lbs.
SHIPPING * WEIGHT	100 lbs.	110 lbs.
SHIPPING * CUBE	8.4 cu ft	8.4 cu ft
ELECTRICAL	(ALL MODELS)	
MOTOR:	12 V 2.3 AMP DC	
BATTERY:	RECHARGABLE MAINTAINANCE FREE 12 V DC	
FUSE/FUSEHOLDER:	12 VT 15A	
* If shipped via common carrier: Shipment via UPS in 3 boxes of:		
Power Unit	1.7 CU FT. 33 LBS	1.7 CU FT. 33 LBS
Container Body	7.2 CU FT 44 LBS	7.2 CU FT 60 LBS
Handle	2.2 CU FT 17 LBS	2.2 CU FT 17 LBS



113 Crosby Road, Ste. #9, Dover NH 03820-4370
Tel: (603) 742-9565 Fax: (603) 742-9608 (800) 332-9565
Email: sales@rfhunter.com Visit our website at: www.rfhunter.com